

NEW

PULL CAM

Panel Avoidance Cam

For Pierce

OUTLINE OF SAPLC

- Compact design for back angle piercing
- Minimal rear space removal and ease of cam slider disassembly
- Spring option : Gas or Coil Spring



Application Example

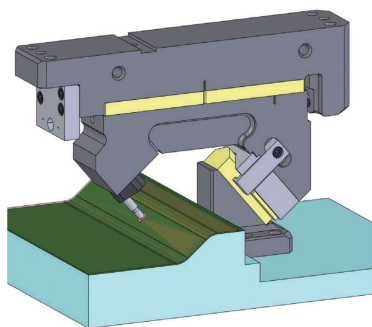

For panels that are difficult to process with normal aerial cam units because the application requires to pierce a hole on a back or reverse angle.

e.g. body side panels
back door panels

Option

- Key specification (-K)
- SAPLC

LKU25-100 (with 1-M8x15 bolt)

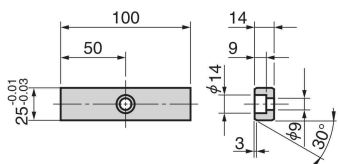

Assembly Instructions

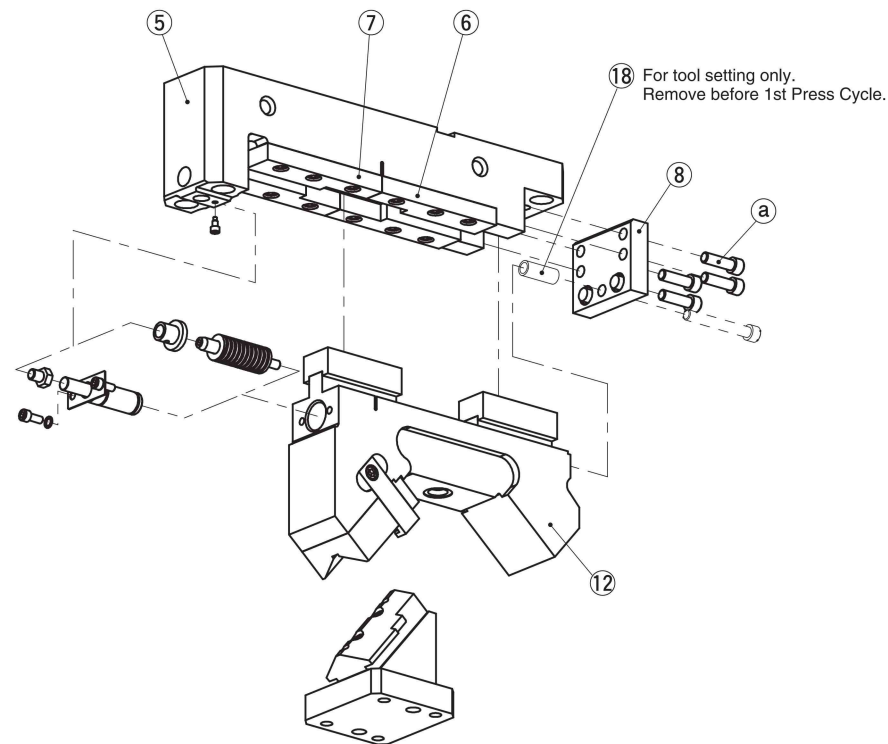

Disassembly

- 1) Remove the Hexagonal Socket Head Bolts (a) to pull out the Stopper Plate (8).
- 2) Slide the Cam Slider (12) back to the corresponding notch placed between (6) and (7).
- 3) Pull up the Cam Slider from the Cam Holder (5).

Assembly

Assembly is the reverse procedure of disassembly.

NOTE · Ensure that all parts are clean, particularly the sliding components to which a small amount of grease is applied and is then placed in position.

- Take care that the respective tolerances are observed when assembling the Cam Slider and Cam Holder, which also should be identified by the same serial number.
- Make sure that all bolts are tighten to the recommended torque after assembly and disassembly.



Gas Spring

Please contact your local sales representative if you prefer to use a gas spring not specified in our catalog. For use and maintenance of gas spring, please contact the manufacturer directly.

Cam Units

SAPLC

NEW

PULL CAM

Panel Avoidance Cam

AERIAL CAM UNIT

For Pierce

SAPLC80

CAD FILE

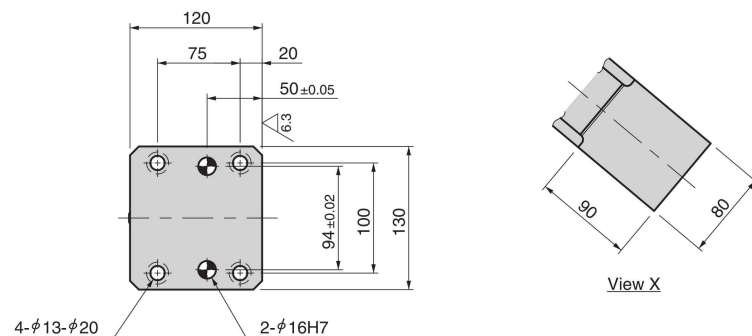
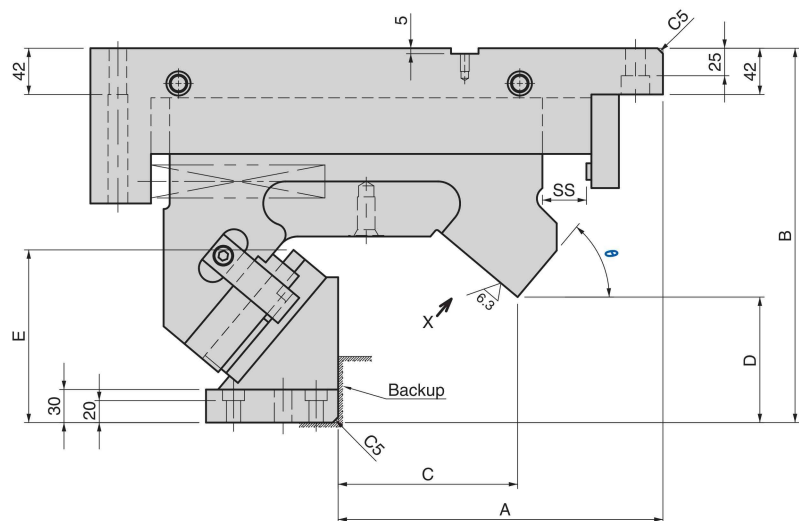
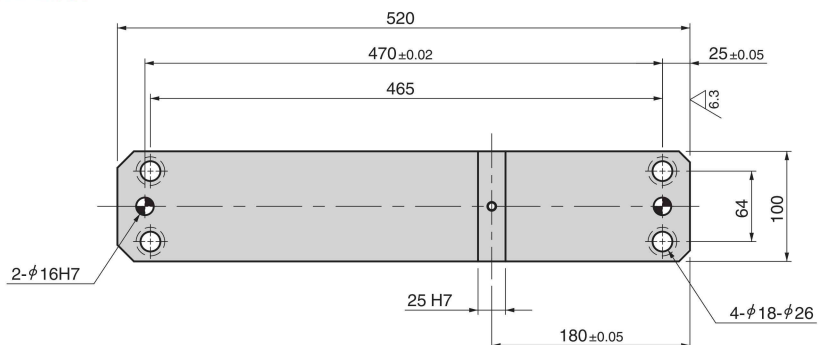

Working Force kN (tonf) 1,000,000 strokes	Catalog No.	W	θ	Spring Type PS
39.2 (4.0)	SAPLC	80	50~80 (5-degree increments)	No Code (Coil Spring) GK NGK GD NGD

No Code:Coil Spring GK:Gas Spring (KALLER) GD:Gas Spring (DADCO)
NGK/NGD:Without Gas Spring Parts for spring assembly are included.

Order	Catalog No.	W	θ	PS	Option
	SAPLC	80	50		
	SAPLC	80	50	GK	NF-K

Option Code	Specification
NF	Nitrogen gas not charged.
K	Key attached.

Refer to page 389 for the machining details of tapped holes and dowel pin holes for retainer mounting.
Refer to page 1 for key specification.

θ	SS	A	B	C	D	E
50		295	340	163	114.0	156.8
55	40	287	340	159	120.5	160.8
60		279	345	155	132.0	163.8
65	34	270		150	140.0	167.8
70	28	260		145	152.5	168.8
75	21	250	350	139	160.0	170.8
80	14	240		133	168.0	169.9

■ Rear Removal Space

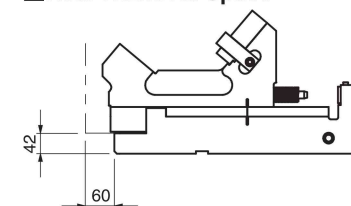

■ Spring force & Return force

● Coil Spring specification

θ	SS	Spring force				Return force			
		Initial Load		Final Load		N	kgf		
		N	kgf	N	kgf				
50					3445.5	351.6			
55	40	440.7	45.0	2644.3	269.8	3748.5	382.5	2558.9	261.1
60						4143.9	422.8		
65	34	503.7	51.4			4672.6	476.8	2396.9	244.6
70	28	587.7	60.0			5403.5	551.4	2462.5	251.3
75	21	330.6	33.7	2644.6	269.9	6462.6	659.4	2588.1	264.1
80	14	587.6	60.0	2644.4	269.8	8112.6	827.8	2427.9	247.7

● Gas Spring specification

Spring force		Return force	
Final Load		Return force	
N	kgf	N	kgf
		3332.1	340.0
2558.9	261.1	3625.1	369.9
		4007.3	408.9
2396.9	244.6	4229.4	431.6
2462.5	251.3	5025.2	512.8
2588.1	264.1	6321.1	645.0
2427.9	247.7	7438.2	759.0

*Coil Spring life expectancy is approx. 300,000 cycles.

*Gas filling pressure is 10 MPa.

Refer to page 6 for parts list.

Cam Units

**SAPLC
80**

NEW

PULL CAM

Panel Avoidance Cam

AERIAL CAM UNIT

For Pierce

SAPLC80

Weight

θ	Cam Slider weight kg	Total weight kg
50	23.2	59.3
55	23.5	59.4
60	23.6	59.9
65	24.3	61.3
70	24.7	62.0
75	25.2	62.7
80		

Cam Diagram

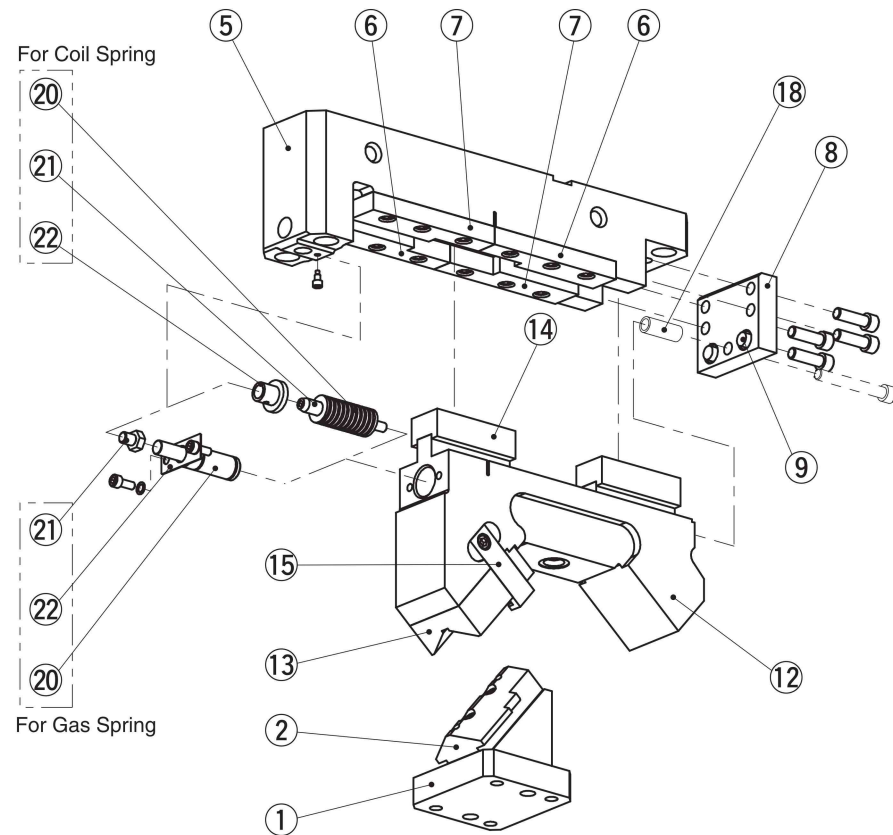
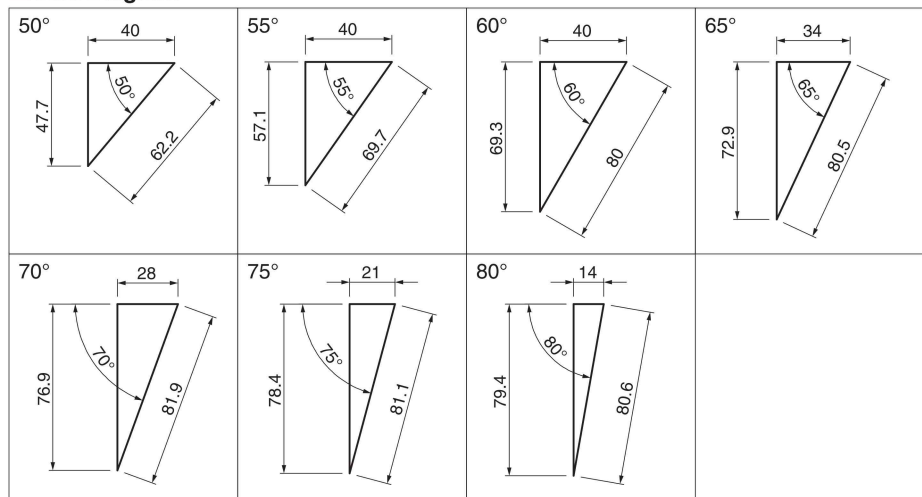

No.	Description	Qty
1	Cam Driver	1
2	Cam Bottom Slide Plate	1
5	Cam Holder	1
6	Cam Upper Plate A	2
7	Cam Upper Plate B	2
8	Stopper Plate	1
9	Urethane Stopper	2
12	Cam Slider	1
13	Cam Bottom Guide Plate	1

No.	Description	Qty
14	Cam Lower Slider	2
15	Positive Return	2
18	Collar	1
20	Coil Spring	1
21	Spring Guide Pin	1
22	Spring Guide Washer	1
20	Gas Spring	1
21	Stop Pin	1
22	Spring Stopper	1

Bolts, dowel pins and washers for assembly are not indicated.

General Description of Additional Machining

AERIAL CAM UNIT OPTION

■ Tapped Hole and Dowel Pin Hole (Prepared Hole, Finish) Machining for Retainer Mounting

- Instruction method for machining
 - Indicate the tapped hole diameter and the dowel pin hole (or prepared hole) diameter with the XY coordinates.
- To indicate the coordinates
 - The origin is positioned at the upper left corner of the mount surface. (However, machining uses our machining datum as the reference.)
 - Indication symbol
 - M**...Tapped hole, **K**...Dowel pin prepared hole, **N**...Dowel pin finish hole
- Machining standard
 - Tapped holes and dowel pin prepared holes are machined to general tolerances.
 - The hole depth is 2.5 times the diameter for both tapped holes and dowel holes. The dowel pilot hole is processed for 2 times the diameter.
 - The dowel pin hole spacing is machined to the tolerance of ± 0.02 . The hole tolerance is H7.

(Example of aerial cam)

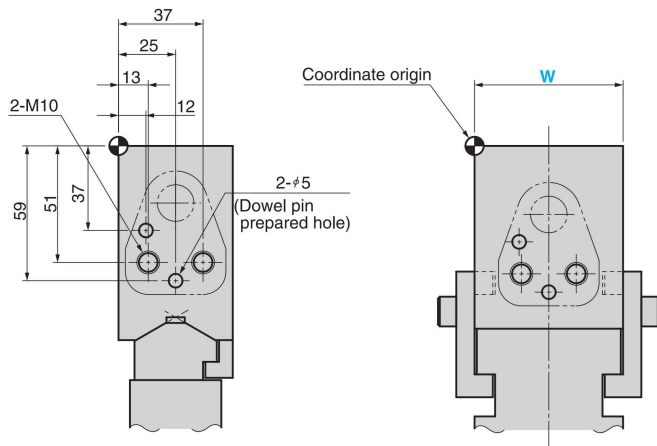

Order	Catalog No.	W	θ	Additional Machining
	SACE	52	00	- M10 - X(13.0) - Y(-51.0) - M10 - X(37.0) - Y(-51.0) - K5.0 - X(12.0) - Y(-37.0) - K5.0 - X(25.0) - Y(-59.0)

(Example of die mounted cam unit)

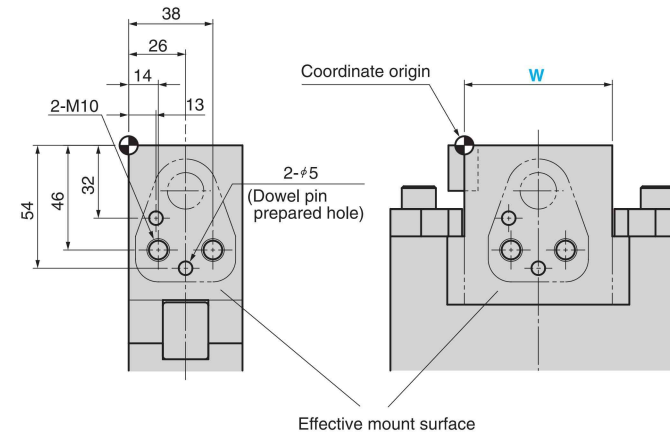

Order	Catalog No.	W	θ	S	Additional Machining
	CMSD	52	00	55	- M10 - X(14.0) - Y(-46.0) - M10 - X(38.0) - Y(-46.0) - K5.0 - X(13.0) - Y(-32.0) - K5.0 - X(26.0) - Y(-54.0)

■ Other machining

Please give instructions on a separate drawing for drilling or cutting other than tapped holes and dowel holes.