

Die Mounted Cam Unit SDCHL

DIE MOUNTED CAM UNIT

Developed for High Tensile Material Applications

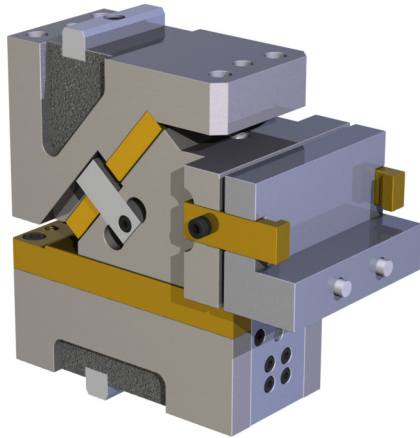

In Comparison to SKCA 100-0-60 :

- Working Force — 3.3 times more, featuring 10tonf Working Force
- Returning Force — Four times more with nitrogen spring
- Mounting surface 170 mm
- Ease of assembly with exposed cam slider

WORKING FORCE DISTRIBUTION DIAGRAM

The working force indicated in the cam face distribution diagram is reached by putting the tooling center of gravity within each area for the following picture.

Working force (kN) allowed for up to 1,000,000 strokes

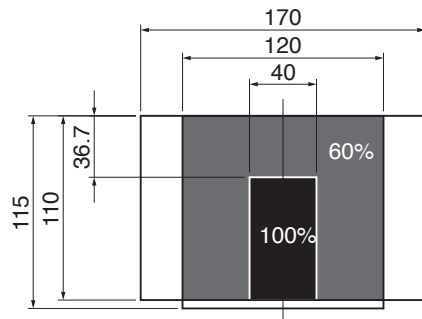

⚠️ Precaution

Do not use for Re-Strike applications. It may break your cam unit.

SDCHL Assembly / Dis-assembly

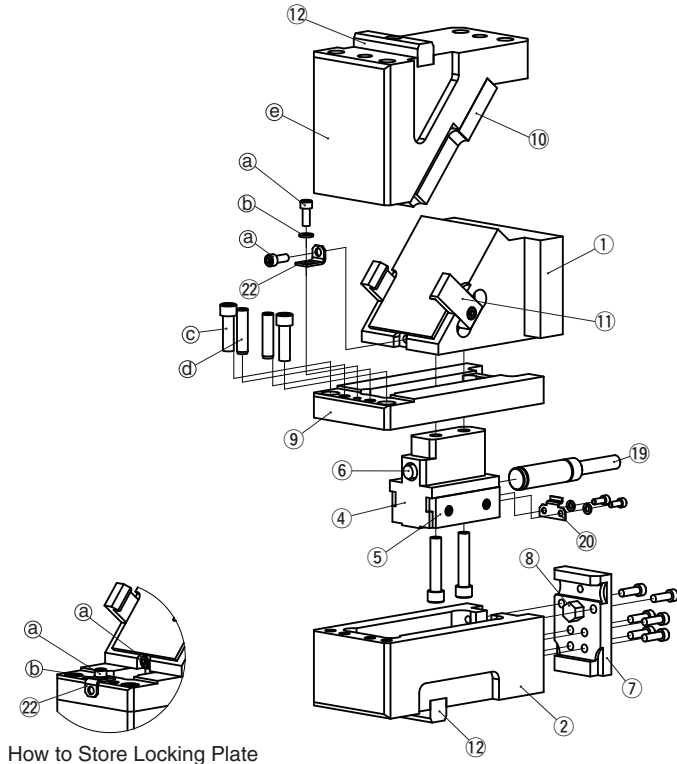

How to Store Locking Plate

Disassembling SDCHL

1. Fasten Cam Slider (1), and Base Plate (9) with Locking Plate (22), Hexagon Socket Head Bolt (a), and Washer (b)
2. Remove Hexagon Socket Head Bolt (c) and Dowel Pin (d)
3. Slide to the rear for 15 mm until Base Plate (9) and Cam Slider (1) are unhooked from Plate (7)
4. Pull up Cam Slider with Base Plate from Cam Holder (2)

Re-assembly

Reassembly is the reverse procedure of disassembly.

- NOTE**
- Ensure that all parts are clean, particularly the sliding components, to which a small amount of grease is applied and is then placed on position.
 - Take care the respective tolerances are observed when assembling the slider and holder, which also should be identified by the same serial number.
 - Ensure that all bolts are tightened to the recommended torque.

⚠️ Gas Spring

Please contact your local sales representative if you prefer to use a gas spring not specified in our catalog. For use and maintenance of gas spring, please contact the manufacturer directly.

Die Mounted Cam Unit SDCHL

DIE MOUNTED CAM UNIT

NEW CAD FILE

SDCHL170-00-55

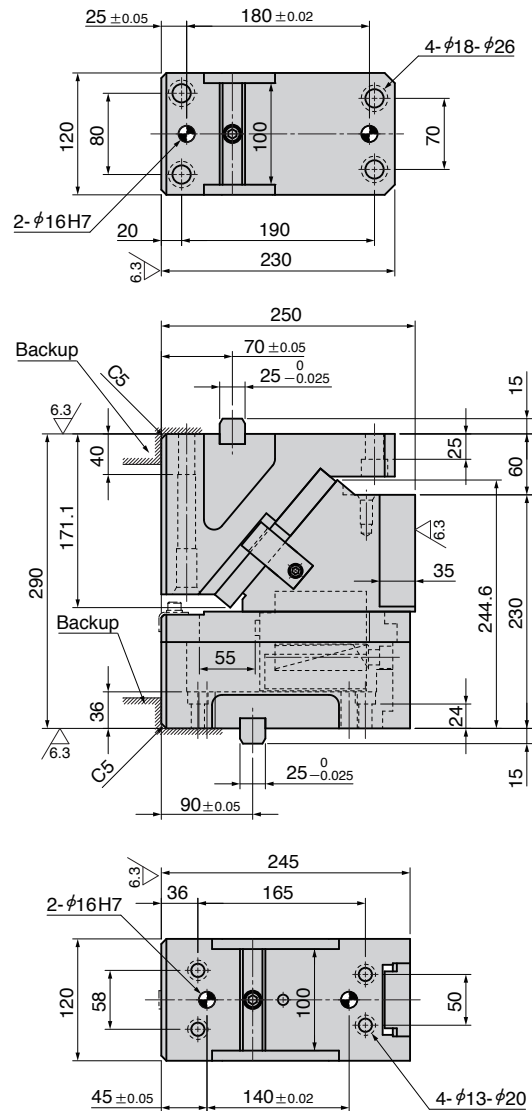

Cam Diagram

*If you do not use the position setting key (12) to the cam unit, backup height 20 mm or more is recommended on Cam Driver and Holder.

SDCHL Specification

Working Force [kN(tonf)] 1,000,000 strokes	Catalog No.	Cam Width W	Angle θ	Travel S	Spring Type PS
98.0(10.0)	SDCHL	170	00	55	GK•NGK

GK : Gas Spring (KALLER) NGK : Without Gas Spring.
Mounting hardware for gas spring included.



Option

Option Code	Specification
NF	Nitrogen gas not charged.



Order

Catalog No.	W	θ	S	PS	Option
SDCHL	170	00	55	GK	NF

▲ Angles above 0° upon request.

Table of Components

No.	Description	Qty
①	Cam Slider	1
②	Cam Holder	1
③	Cam Driver	1
④	Cam Lower Slider	1
⑤	Slide Plate	2
⑥	Urethane Stopper	1
⑦	Plate	1
⑧	Stop Pin	1
⑨	Base Plate	1
⑩	Driver Plate	1
⑪	Positive Return Plate	2
⑫	Key	2
⑰	Gas Spring	1
⑳	Spring Stopper	1
㉓	Locking Plate	1

Gas Spring Specification

Angle	Spring Travel SS	Final Pressure		Model
		N	kgf	
00	55	4966.7	506.8	X320-63

*Gas charging pressure:18 MPa

Space for removing

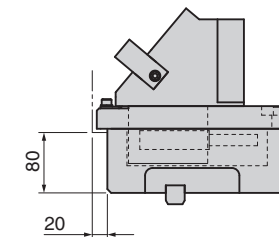

Weight

Angle	Slider [kg]	Total [kg]
00	17.4	54.9