



Product Information

- Compared with the VALCAM White, the overall front-to-back length is reduced by approximately 30%.
- Cam unit weight: 3.6~3.9kg.
- For piercing only.
- Endurance of 1 million strokes.
- Working force: 14.7 kN (1.5 tonf).
- Spring Option: Gas or Coil Spring.



Mount Face Width mm	Working Force kN (tonf) 1,000,000 strokes	Working Angle 5° increments	Catalog No.	Spring Type	Application
46	14.7 (1.5)	0°~50°	VACXSW46		

 Gas Spring  Coil Spring

Features

Redefining the Standards of Size

Through a complete redesign of the internal structure and precise optimization of component shapes, we have achieved further downsizing and weight reduction while maintaining the same processing force as the White model.

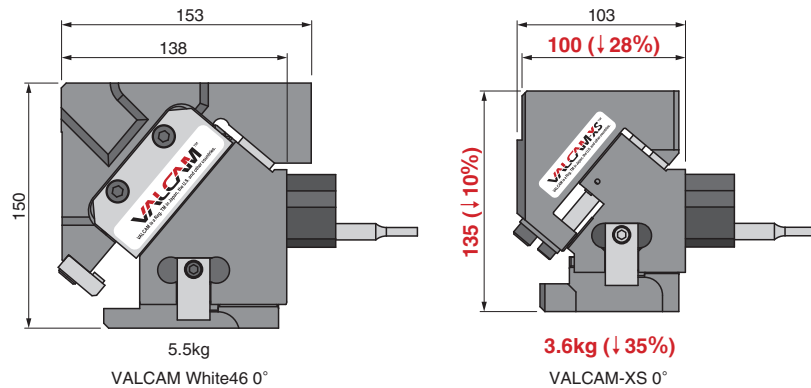

A Cam Unit True to Fundamental Performance

Because cam units are widely used for piercing applications, we focused on a design that firmly adheres to the fundamentals. Durability, precision, and operability are all refined to a high level, ensuring stable processing quality.

- **Compatible with high-speed production & Endurance: 1 million strokes**
A long-life design that meets the demanding requirements of production environments.
 - **V-guide structure**
Delivers stable guiding accuracy and smooth operation.
 - **User-friendly design for improved operability**
A highly maintainable structure that allows for quick and easy servicing.
 - **Optional extended mount face**
Supports flexible layouts even with compact units.
 - **Optional lock system**
By installing the accessory parts, the bottom dead center position can be reproduced.
-  Refer to page 22 for Assembly instructions.

Benefits of Introducing VALCAM-XS

Interference Avoidance & Reduced Design Burden

In areas where conventional cam units often interfere such as the rear section in wheel-arch regions or where rear-clearance space cannot be secured when positioned behind the back-door inner window VALCAM-XS enables feasible layouts thanks to its exceptionally short front-to-back length. Even in challenging tooling design locations, VALCAM-XS provides a practical solution.

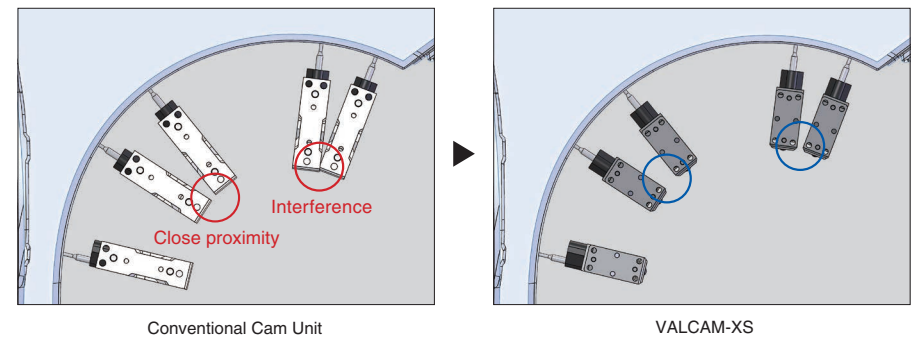

Product Information

Contributing to Reduced Die Weight

Because the front-to-back dimension is significantly shorter than that of conventional cam units, the seating area for the cam unit can be reduced, enabling a more compact die design and ultimately lowering overall die weight.

In piercing operations for door inners and body-side panels where many cam units are typically required the lighter body of the VALCAM-XS further contributes to reducing the total die weight.

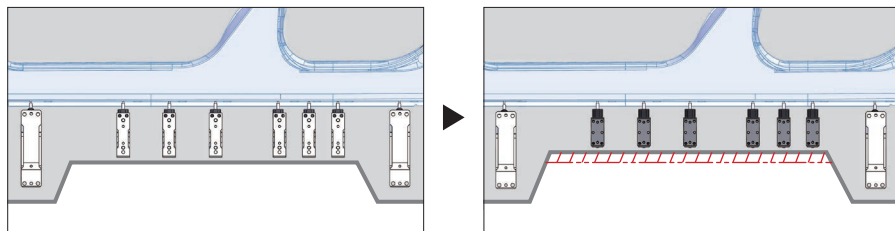

Conventional Cam Unit

VALCAM-XS

Improved Workability and Ease of Maintenance

Thanks to a simple guide structure using a copper-alloy bush, the VALCAM-XS achieves a cam-slider weight of just 1.3 kg, which is 35% lighter than the VALCAM White. The total cam-unit weight is kept below 4.0 kg for all angles.

This lightweight design, combined with a highly serviceable assembly/disassembly structure, makes punch alignment, and maintenance operations significantly smoother, greatly reducing operator workload.

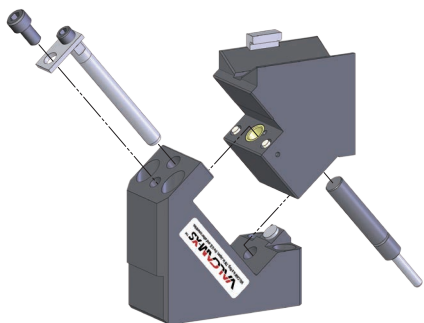

High Reliability Specialized for Piercing

By efficiently distributing processing forces and enhancing durability through an optimized design, the VALCAM-XS maintains the same level of processing performance as the VALCAM White—despite its compact size. In addition, the combination of a simple round guide using a proven copper-alloy bush and a V-guide structure ensures stable guiding accuracy and smooth motion. Its rigidity and stability remain uncompromised even at a smaller size, allowing safe and reliable use of the extended mounting-surface option.

Standard Durability of Coil Spring

Coil Springs used in VALCAM-XS require maintenance on a regular basis and their durability expires at 300,000 cycles as a rule of thumb. Please note that the durability is based on the tests run by the manufacturer of the Coil Springs and that it's merely an assumption based on such tests. Depending on how the product has been actually used in a particular environment, Coil Springs can break earlier than 300,000 cycles. Regular monitoring and maintenance on Coil Spring are highly recommended.

Example: When it's used with over strokes, the Coil Spring will break earlier due to too much deflection.

Roughness of Sliding Surface

Machining marks on sliding surface may look rough, but surface roughness is within our standard. We guarantee the quality of our products through testing and experience.

Aerial Cam Unit

Working Force [kN (tonf)] 1,000,000 strokes	Catalog No.	W	θ 5° increments	Spring Type PS
14.7 (1.5)	VACXSW	46	00~50	No Code (Coil Spring) GK NGK GD NGD GSS NGSS

No Code: Coil Spring GK: Gas Spring (KALLER) GD: Gas Spring (DADCO) GSS : Gas Spring (Special Springs)
NGK/NGD/NGSS: Without Gas Spring Parts for spring assembly are included.



Order

Catalog No.	W	θ	PS	Option
VACXSW	46	00		
VACXSW	46	00	GK	
VACXSW	46	00	NGD	SC50
VACXSW	46	00	GSS	NF-SC50-S



Option

Option Code	Specification
NF	Nitrogen gas not charged.
SC	Mount face length is extended from 1 to 60 mm in increments of 1 mm.
S	Lock plate attached.

■ Spring Force & Return Force

● Coil Spring

θ	Initial Load		Final Load		Return Force		Spring Model
	N	kgf	N	kgf	N	kgf	
00	52.2	5.3	283	28.9	364	37.2	TM12-90
05	52.2	5.3	283	28.9	363	37.1	TM12-90
10	52.2	5.3	283	28.9	362	36.9	TM12-90
15	52.2	5.3	283	28.9	361	36.8	TM12-90
20	52.2	5.3	283	28.9	360	36.7	TM12-90
25	52.2	5.3	283	28.9	358	36.5	TM12-90
30	52.2	5.3	283	28.9	357	36.4	TM12-90
35	52.2	5.3	283	28.9	355	36.3	TM12-90
40	52.2	5.3	283	28.9	354	36.1	TM12-90
45	52.2	5.3	283	28.9	352	36.0	TM12-90
50	52.2	5.3	283	28.9	351	35.8	TM12-90

Life expectancy of Coil Spring is approximately 300,000 strokes.

● Gas Spring

θ	Final Load		Return Force		Spring Model
	N	kgf	N	kgf	GK
00	515	52.6	657	67.1	R12-25-RED
05	515	52.6	656	66.9	R12-25-RED
10	515	52.6	655	66.8	R12-25-RED
15	515	52.6	654	66.7	R12-25-RED
20	515	52.6	652	66.6	R12-25-RED
25	515	52.6	651	66.4	R12-25-RED
30	515	52.6	649	66.3	R12-25-RED
35	515	52.6	648	66.1	R12-25-RED
40	515	52.6	647	66.0	R12-25-RED
45	515	52.6	645	65.8	R12-25-RED
50	515	52.6	644	65.7	R12-25-RED

Gas filling pressure: 13.5 Mpa

θ	Final Load		Return Force		Spring Model
	N	kgf	N	kgf	GD
532	54.3	679	69.2	C.045.025.RD	
532	54.3	677	69.1	C.045.025.RD	
532	54.3	676	69.0	C.045.025.RD	
532	54.3	675	68.9	C.045.025.RD	
532	54.3	674	68.7	C.045.025.RD	
532	54.3	672	68.6	C.045.025.RD	
532	54.3	671	68.5	C.045.025.RD	
532	54.3	669	68.3	C.045.025.RD	
532	54.3	668	68.2	C.045.025.RD	
532	54.3	667	68.0	C.045.025.RD	
532	54.3	665	67.9	C.045.025.RD	

Gas filling pressure: 13.2 Mpa

θ	Final Load		Return Force		Spring Model
	N	kgf	N	kgf	GSS
00	572	58.4	729	74.4	M50-025-A-RD
05	572	58.4	728	74.2	M50-025-A-RD
10	572	58.4	726	74.1	M50-025-A-RD
15	572	58.4	725	74.0	M50-025-A-RD
20	572	58.4	724	73.9	M50-025-A-RD
25	572	58.4	722	73.7	M50-025-A-RD
30	572	58.4	721	73.6	M50-025-A-RD
35	572	58.4	720	73.4	M50-025-A-RD
40	572	58.4	718	73.3	M50-025-A-RD
45	572	58.4	717	73.1	M50-025-A-RD
50	572	58.4	715	73.0	M50-025-A-RD

Gas filling pressure: 13.5 Mpa

Aerial Cam Unit

Cam Travel

θ	Travel mm
00	15.1
05	16.7
10	18.3
15	19.9
20	21.7
25	23.5
30	25.5
35	27.7
40	30.2
45	33.1
50	36.6

Weight*1

θ	Total Weight kg	Cam Slider Weight kg	Max. Tool Weight*2 kg
00	3.6	1.3	2.1
05	3.6	1.3	2.1
10	3.6	1.3	2.1
15	3.6	1.3	2.1
20	3.6	1.3	2.1
25	3.6	1.3	2.1
30	3.6	1.3	2.1
35	3.7	1.3	2.1
40	3.7	1.3	2.1
45	3.8	1.3	2.1
50	3.9	1.3	2.1

*1 This is the weight without SC option. Reduce tool weight when with SC option since the slider gets heavier.

*2 Tool weight is estimated value. Allowable tool weight varies depending on press speed.

Rear Removal Space

- Coil Spring
- Gas Spring

θ	L1 mm	L2 mm
00	48.5	165.9
05	55.9	155.8
10	63.2	144.8
15	70.3	132.1
20	76.2	119.7
25	81.8	105.8
30	86.1	92.4
35	90.0	79.7
40	93.6	65.9
45	96.7	52.9
50	98.5	40.0

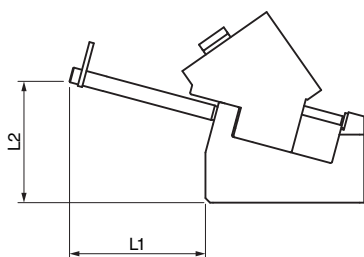

VACXSW46 Assembly Instructions

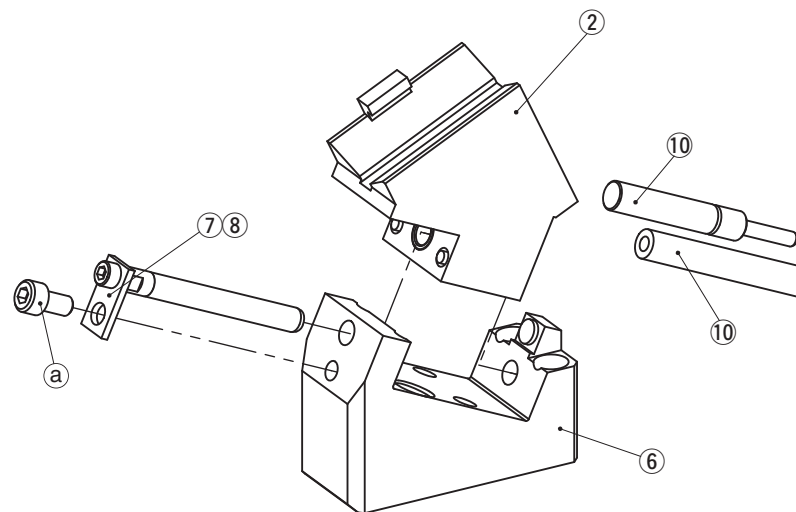

Disassembly

- 1) Loosen hexagonal socket head bolts (a) and remove Guide bar, Plate (7, 8).
- 2) Pull out and remove Cam Slider (2) from Cam Holder (6) to the rear.
 - * Note that the Coil Spring (10) and Gas Spring (10) is not fixed to Cam Slider.

Assembly

Assembly is the reverse procedure of disassembly.

- Ensure that all parts are clean, particularly the sliding components to which a small amount of lubricant is applied and is then placed in position.
- Take care that the respective tolerances are observed when assembling Cam Slider and Cam Holder, which also should be identified by the same serial number.
- When installing the coil spring, ensure that it is fully seated in the spring seat of the cam holder.
- Make sure that all bolts are tighten to the recommended torque after assembly and disassembly.

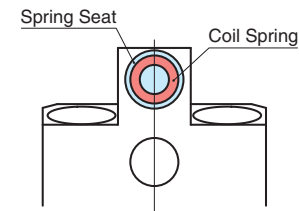

Gas Spring

Please contact your local sales representative if you prefer to use a gas spring not specified in our catalog. For use and maintenance of gas spring, please contact the manufacturer directly.

Aerial Cam Unit

VACXSW46-00

CAD FILE

● Cam Diagram

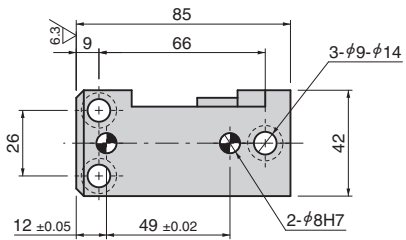
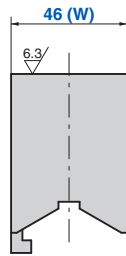
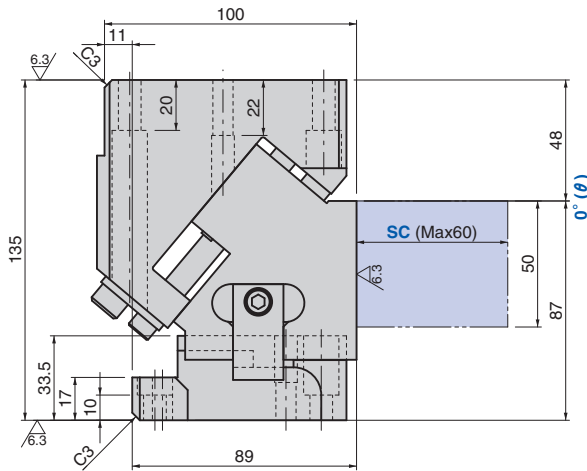
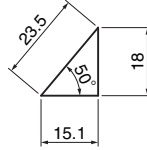
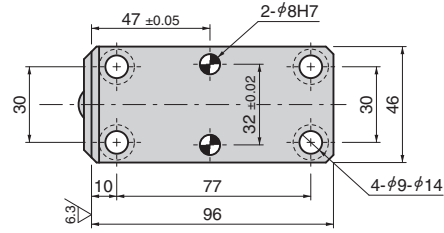

VACXSW46-05

CAD FILE

● Cam Diagram

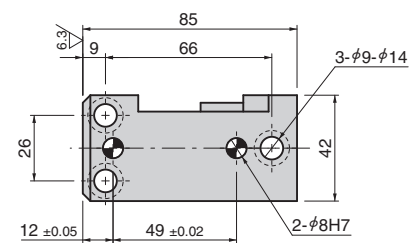
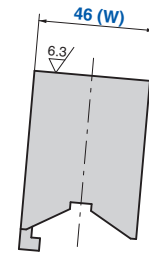
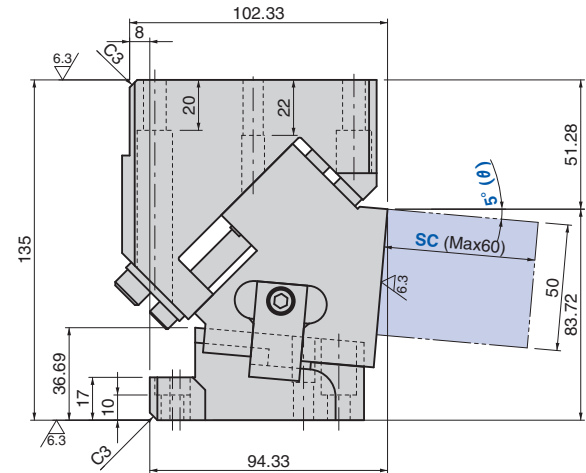
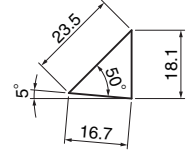
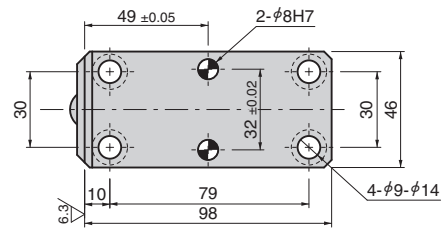

Refer to page 22 for Table of Components.

Refer to page 22 for Table of Components.

Aerial Cam Unit

CAD FILE

VACXSW46-10

● Cam Diagram

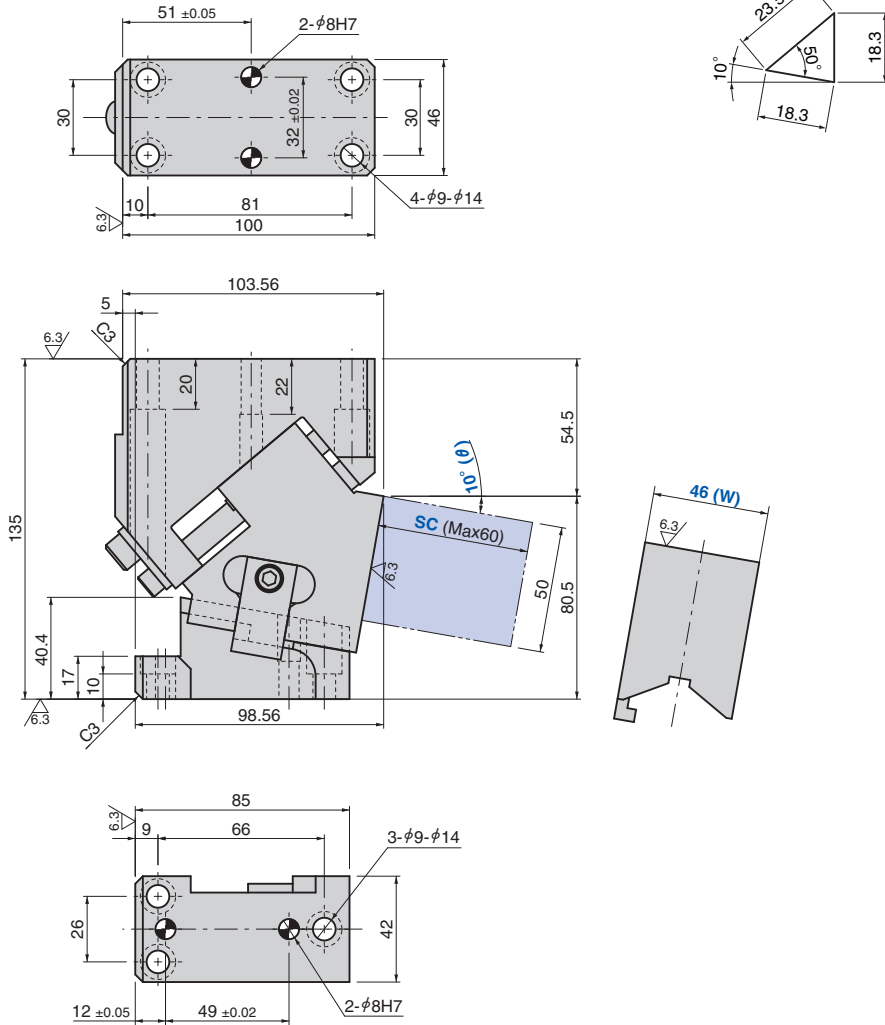

CAD FILE

VACXSW46-15

● Cam Diagram

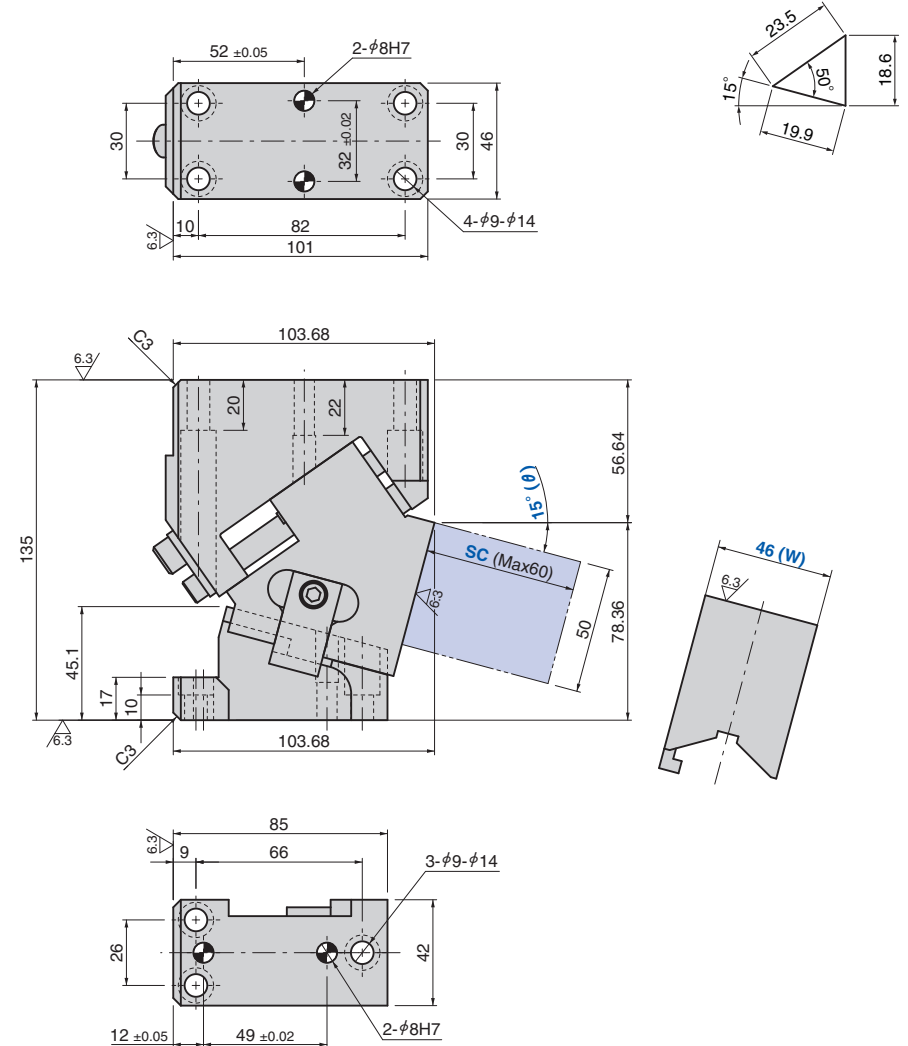

Aerial Cam Unit

VACXSW46-20

CAD FILE

● Cam Diagram

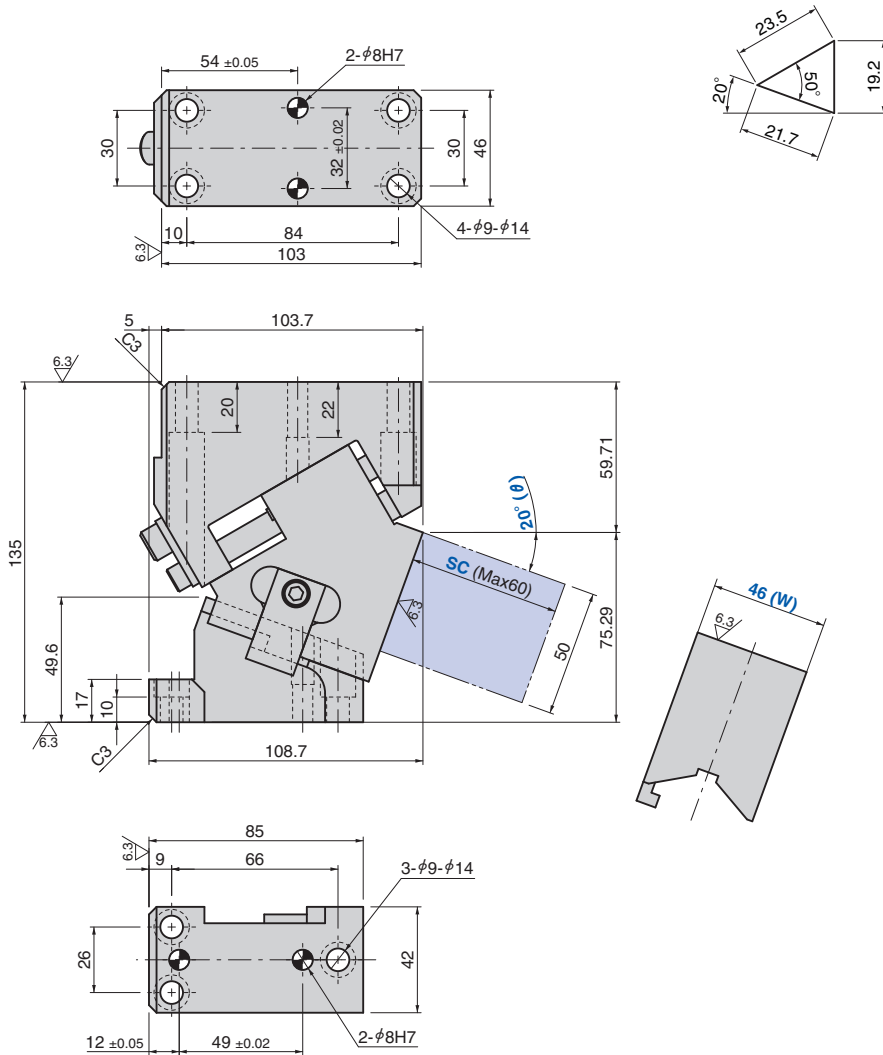

VACXSW46-25

CAD FILE

● Cam Diagram

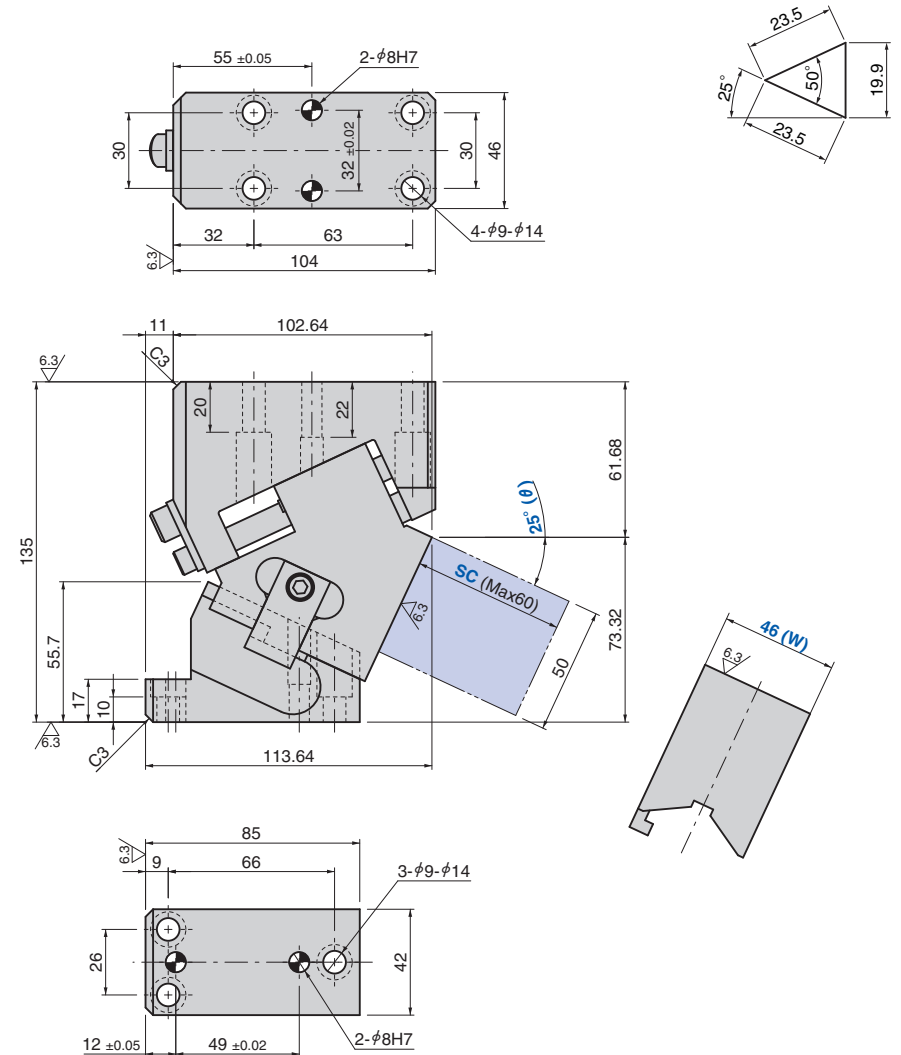

Aerial Cam Unit

VACXSW46-30

CAD FILE

● Cam Diagram

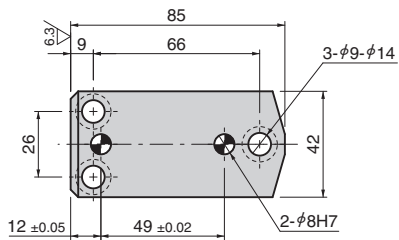
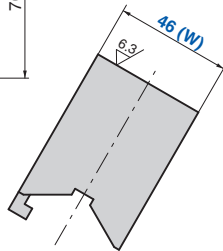
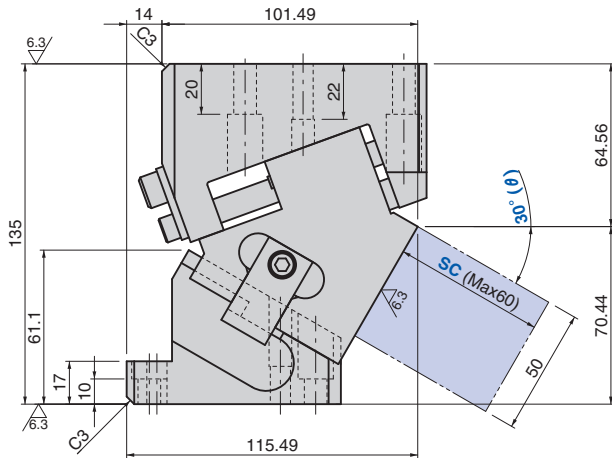
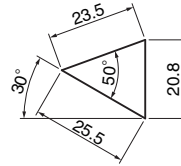
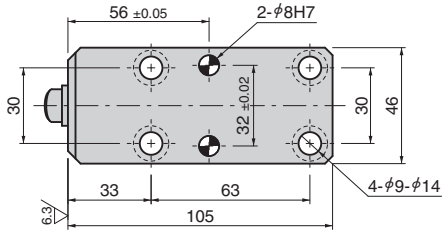

VACXSW46-35

CAD FILE

● Cam Diagram

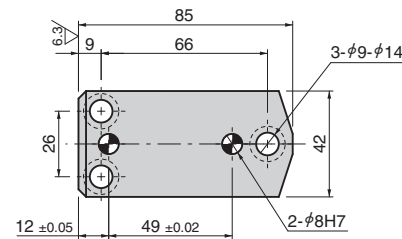
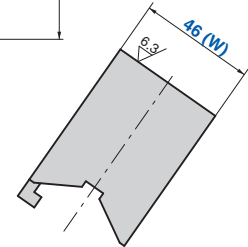
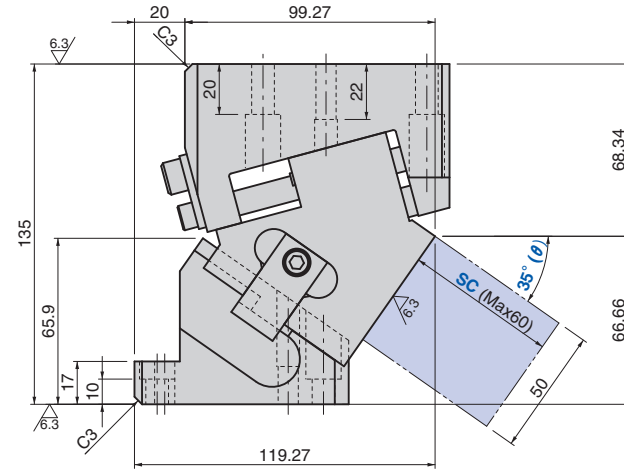
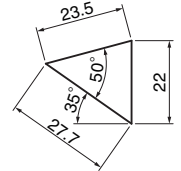
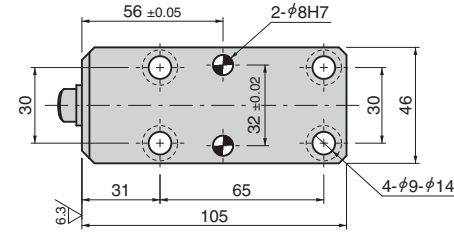

Refer to page 22 for Table of Components.

Refer to page 22 for Table of Components.

Aerial Cam Unit

VACXSW46-40

CAD FILE

VACXSW46-45

CAD FILE

● Cam Diagram

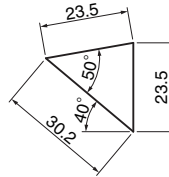

● Cam Diagram

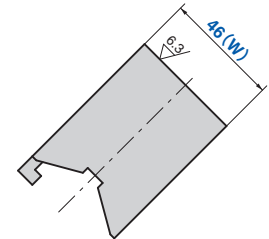
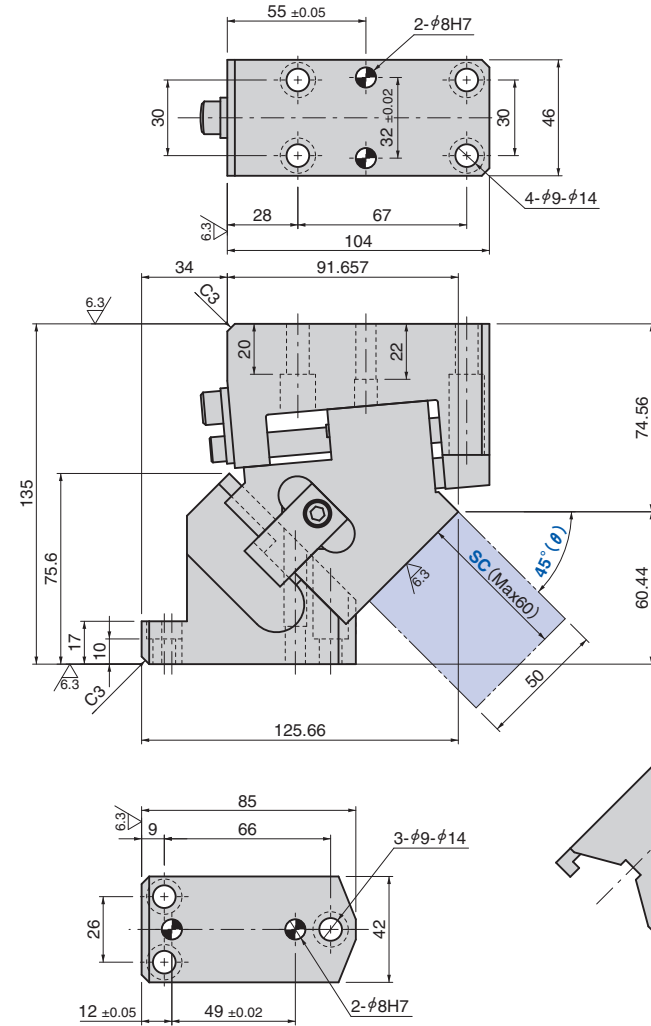
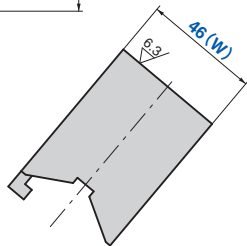
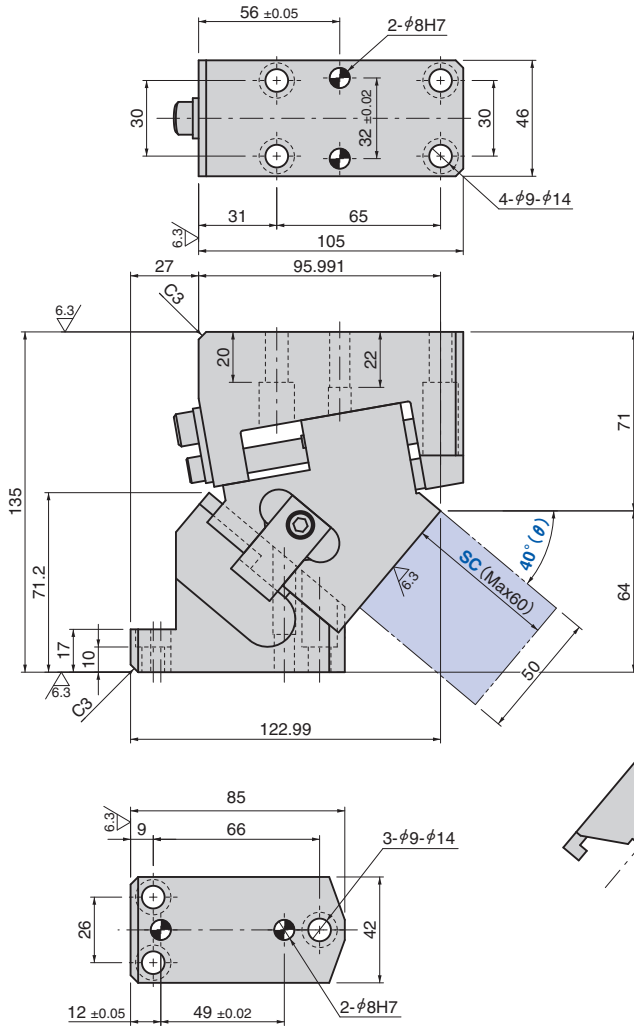
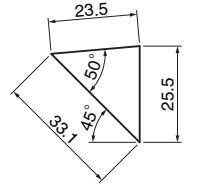

▶ Refer to page 22 for Table of Components.

▶ Refer to page 22 for Table of Components.

Aerial Cam Unit

VACXSW46-50



● Cam Diagram

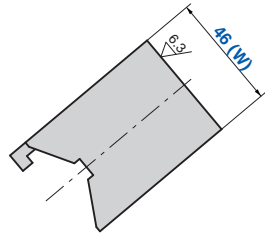
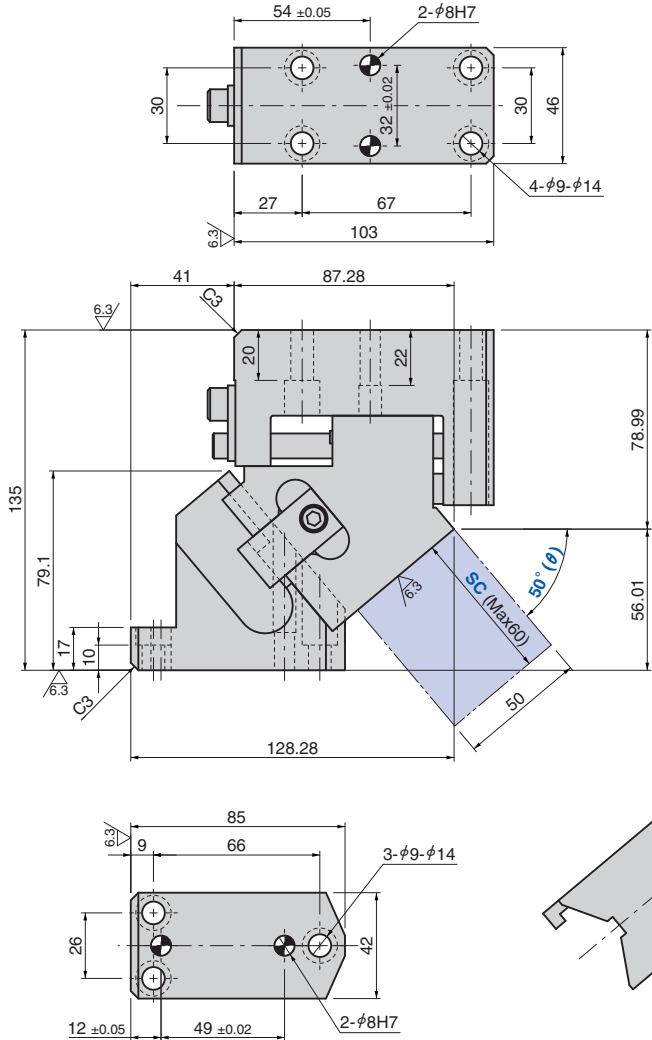
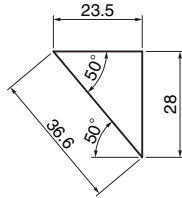

▶ Refer to page 22 for Table of Components.

Aerial Cam Unit

VACXS46

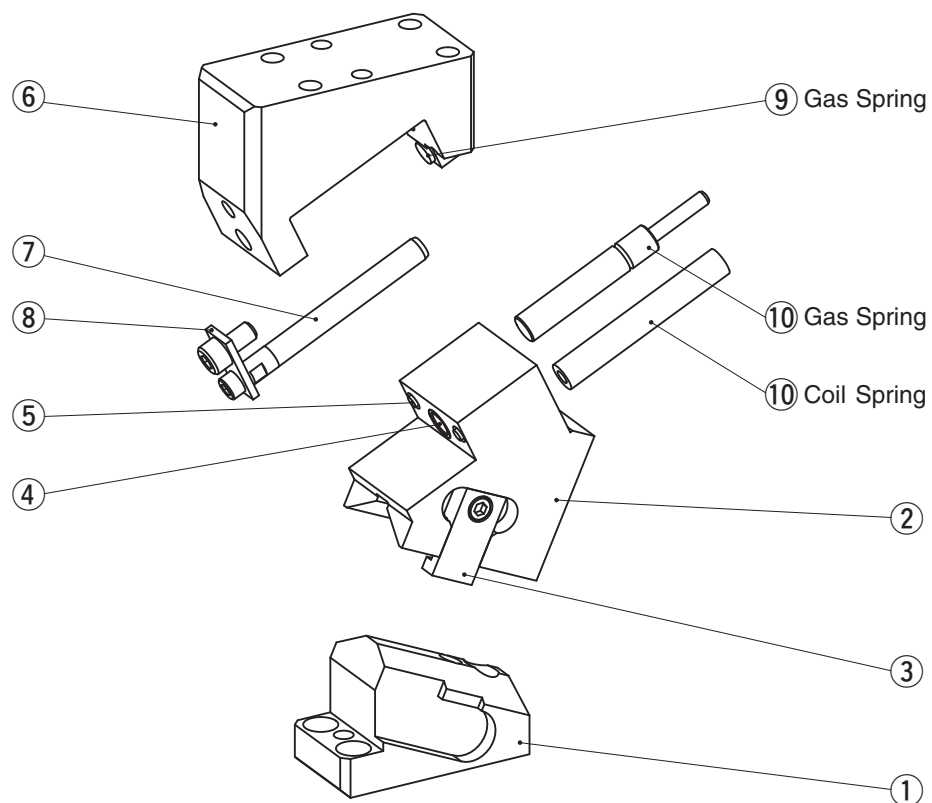

● Lock System

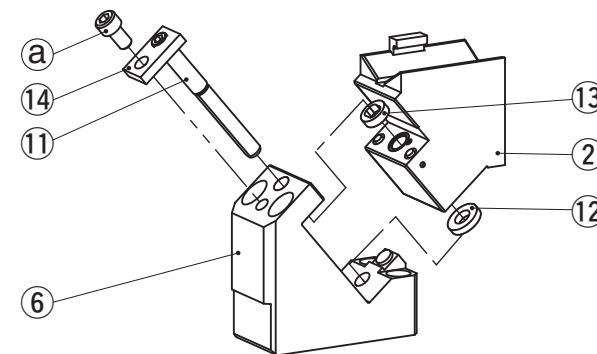

● Lock System Assembly

- 1) Assemble Lock Plate (14) and Lock Pin (11).
- 2) Place Washer (12), Cam Slider (2), and Washer (13) on Cam Holder (6) and pass the Lock Pin through.
* Note the installation position of the Washers (12) and (13).
- 3) Secure the Plate with hexagonal socket head bolts (a).
- 4) Insert a hexagonal wrench into the hexagonal socket on the end of the Lock Pin and rotate it clockwise until the Cam Slider is secured.

No.	Description	Qty	
		Coil Spring	Gas Spring
1	Cam Driver		1
2	Cam Slider		1
3	Positive Return Plate		1
4	Bush		2
5	Stopper		2
6	Cam Holder		1
7	Guide Bar		1
8	Plate		1
9	Stop pin	—	1
10	Coil Spring	1	—
10	Gas Spring	—	1
11	Lock Pin		1
12	Washer		1
13	Washer		1
14	Lock Plate		1

Bolts for assembly are not indicated.